

**Linear Tracking
Full Automatic
Programmable Turntable**

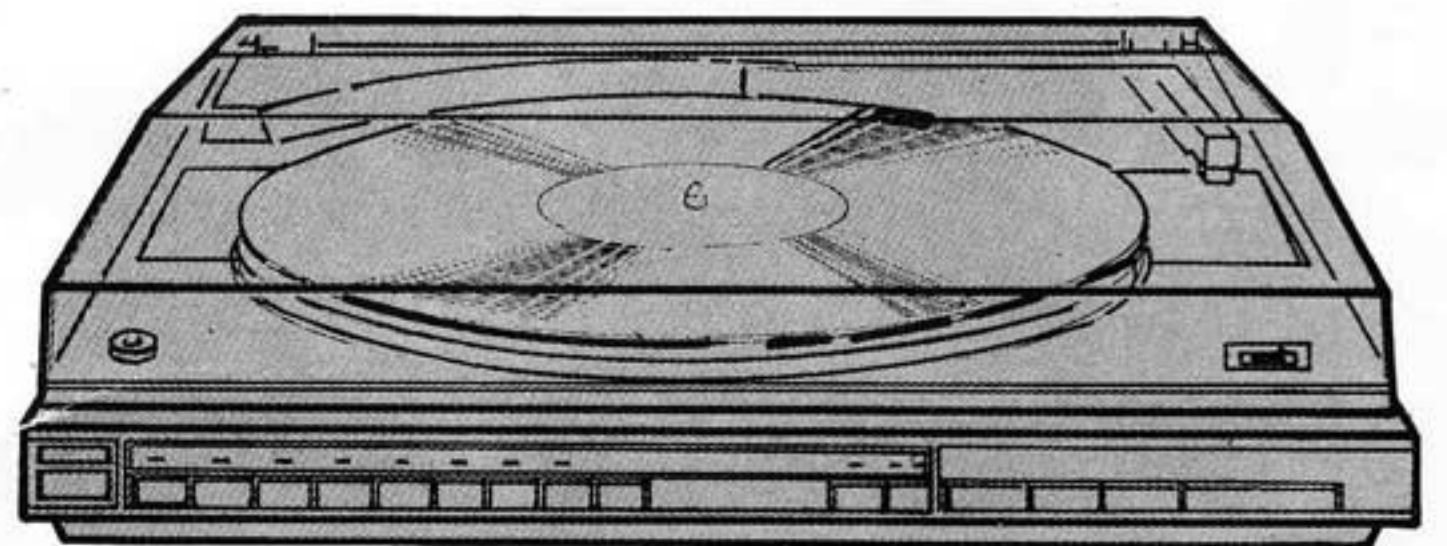

XL-1200



Safety Precautions

WARNING: TO PREVENT FIRE OR ELECTRIC SHOCK, DO NOT EXPOSE THIS APPLIANCE TO RAIN OR MOISTURE.



CAUTION
RISK OF ELECTRIC SHOCK
DO NOT OPEN



CAUTION: TO REDUCE THE RISK OF ELECTRIC SHOCK, DO NOT REMOVE COVER (OR BACK). NO USER-SERVICEABLE PARTS INSIDE. REFER SERVICING TO QUALIFIED SERVICE PERSONNEL.



Explanation of Graphical Symbols

The lightning flash with arrowhead symbol, within an equilateral triangle, is intended to alert the user to the presence of uninsulated "dangerous voltage" within the product's enclosure that may be of sufficient magnitude to constitute a risk of electric shock to persons.

The exclamation point within an equilateral triangle is intended to alert the user to the presence of important operating and maintenance (servicing) instructions in the literature accompanying the appliance.

IMPORTANT SAFEGUARDS

SAFETY POINTS YOU SHOULD KNOW ABOUT YOUR AUDIO EQUIPMENT.

CAUTION:

- Read all of these instructions.
- Save these instructions for later use.
- Follow all warnings and instructions marked on the audio equipment.

1. **Read Instructions**—All the safety and operating instructions should be read before the appliance is operated.
2. **Retain Instructions**—The safety and operating instructions should be retained for future reference.
3. **Heed Warnings**—All warnings on the appliance and in the operating instructions should be adhered to.
4. **Follow Instructions**—All operating and use instructions should be followed.
5. **Water and Moisture**—The appliance should not be used near water—for example, near a bathtub, washbowl, kitchen sink, laundry tub, in a wetbasement, or near a swimming pool, etc.
6. **Carts and Stands**—The appliance should be used only with a cart or stand that is recommended by the manufacturer.
- 6A. An appliance and cart combination should be moved with care. Quick stops, excessive force, and uneven surfaces may cause the appliance and cart combination to overturn.

PORTABLE CART WARNING



7. **Wall or Ceiling Mounting**—The appliance should be mounted to a wall or ceiling only as recommended by the manufacturer.
8. **Heat**—The appliance should be situated away from heat sources such as radiators, heat registers, stoves, or other appliances (including amplifiers) that produce heat.
9. **Ventilation**—The appliance should be situated so that its location or position does not interfere with its proper ventilation. For example, the appliance should not be situated on a bed, sofa, rug, or similar surface that may block the ventilation openings; or, placed in a built-in installation, such as a bookcase or cabinet that may impede the flow of air through the ventilation openings.
10. **Power Sources**—The appliance should be connected to a power supply only of the type described in the operating instructions or as marked on the appliance.
11. **Grounding or Polarization**—The precautions that should be taken so that the grounding or polarization means of an appliance is not defeated.
12. **Power-Cord Protection**—Power-supply cords should be routed so that they are not likely to be walked on or pinched by items placed upon or against them, paying particular attention to cords at plugs, convenience receptacles, and the point where they exit from the appliance.

13. **Cleaning**—The appliance should be cleaned only as recommended by the manufacturer.
14. **Power Lines**—An outdoor antenna should be located away from power lines.
15. **Outdoor Antenna Grounding**—If an outside antenna is connected to the receiver, be sure the antenna system is grounded so as to provide some protection against voltage surges and built up static charges. Section 810 of the National Electrical Code, ANSI/NFPA No. 70—1984, provides information with respect to proper grounding of the mast and supporting structure, grounding of the lead-in wire to an antenna discharge unit, size of grounding conductors, location of antenna-discharge unit, connection to grounding electrodes, and requirements for the grounding electrode. See Figure below.

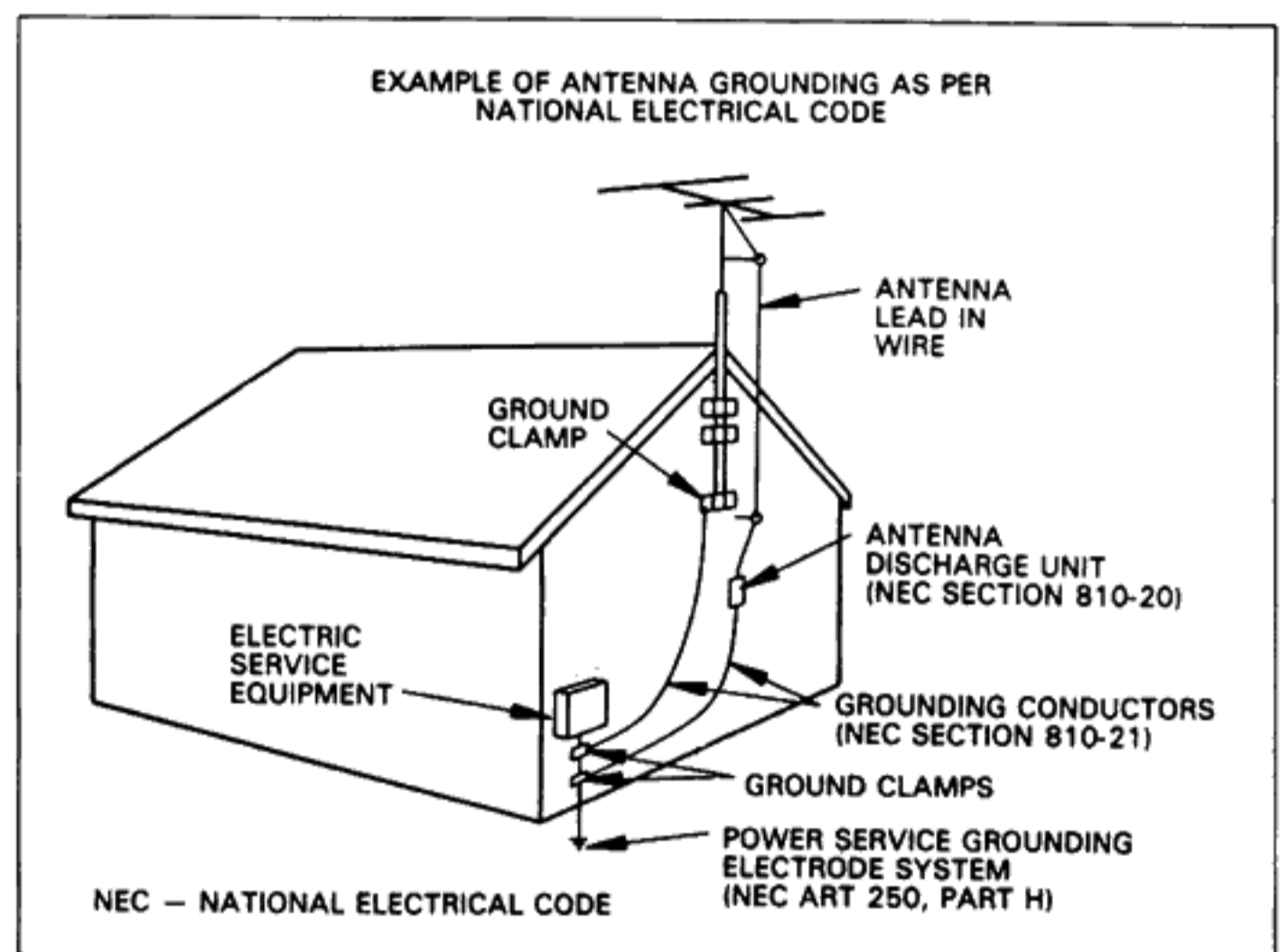

16. **Nonuse Periods**—The power cord of the appliance should be unplugged from the outlet when left unused for a long period of time.
17. **Object and Liquid Entry**—Care should be taken so that objects do not fall and liquids are not spilled into the enclosure through openings.
18. **Damage Requiring Service**—The appliance should be serviced by qualified service personnel when:
 - A. The power-supply cord or the plug has been damaged; or
 - B. Objects have fallen, or liquid has been spilled into the appliance; or
 - C. The appliance has been exposed to rain; or
 - D. The appliance does not appear to operate normally or exhibits a marked change in performance; or
 - E. The appliance has been dropped, or the enclosure damaged.
19. **Servicing**—The user should not attempt to service the appliance beyond that described in the operating instructions. All other servicing should be referred to qualified service personnel.

Contents

Safety Precautions	2
Important Safeguards	3
Turntable Features	4
Turntable Installation	5
Operating Controls	6
Manual Operation	7
Additional Information	9
For Continued Enjoyment	10
Trouble Checks	10
Specifications	11
Transporting the Turntable	11
Removing Dust Cover	11

Turntable Features

Linear Tracking Tonearm

The linear tracking tonearm moves the way the cutting head in a record-master cutting machine does. Tracking error and distortion are reduced to a minimum—and your prized records are protected from unnecessary wear. Tracking force is just 2 grams.

Tonearm Muting

A muting switch eliminates any noise which might be produced when the stylus is raised from or lowered to the record surface.

Automatic Size and Speed Selection

The Turntable's optical system detects record size and automatically selects the correct turntable speed: 33 1/3 RPM for your 12" records and 45 RPM for 7" records.

Manual override is available for playing transparent records and other non-standard records.

Programmed Play

You can play up to eight selections on a record in any sequence you choose, repeating some or all of them for up to a total of fifteen selections.

Direct Access Play

You can begin play at the start of any track on a record (up to the eighth selection) and continue play till the end of the record.

Repeat Play

You can repeat the entire record (or the selections you have programmed) up to sixteen times.

Turntable Installation



Model XL-1200 Turntable.

Location

Choose a location away from heat sources such as direct sunlight and heating units. Do not mount the Turntable (or any other components) directly above a stereo amplifier or receiver because excessive heat may rise from them. If your Turntable is to be rack-mounted with other components, be sure that there is adequate ventilation at the back and around the sides of all components.

Your Turntable should be placed on a solid, level surface for best operation. Turntable placement on top of a speaker cabinet is not recommended; vibrations may be transmitted to the platter and tonearm, resulting in sound distortion and feedback.

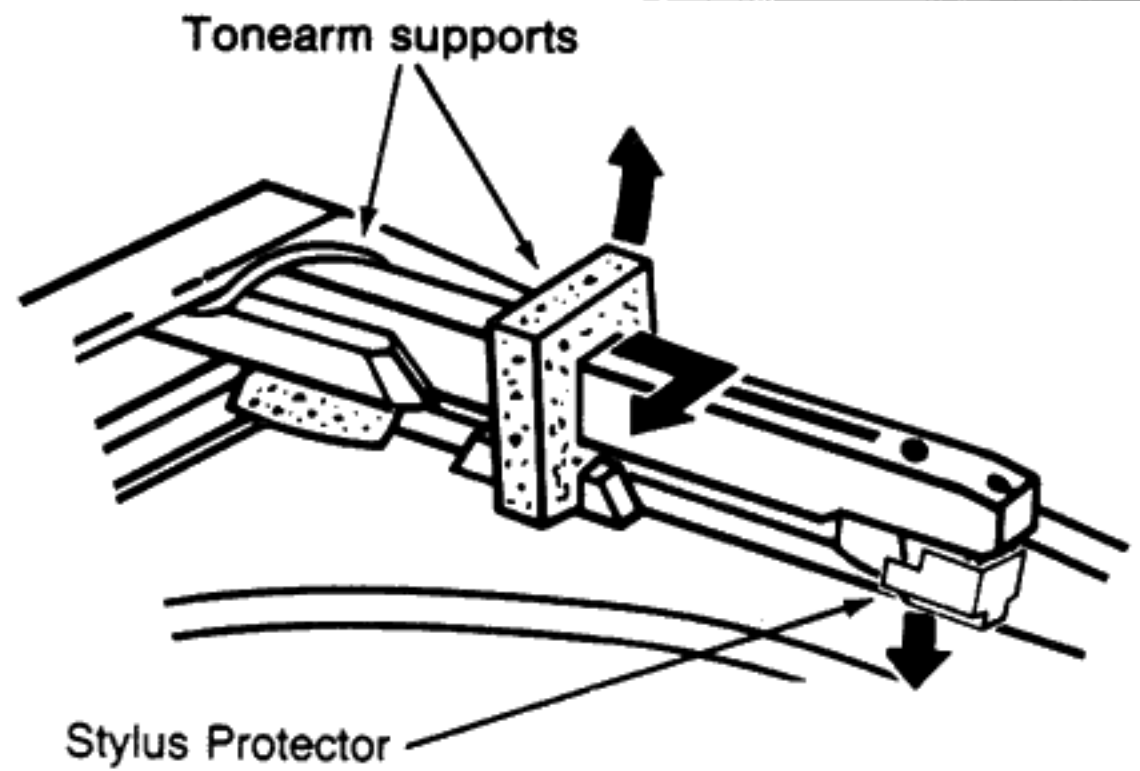

(B) Tonearm Supports

Be careful not to damage the stylus when you perform the following steps. If you accidentally dislodge the stylus, refer to the instructions for stylus replacement on Page 7.

1. Referring to the illustration above, identify the points on the tonearm supports before you attempt to remove them.
2. Remove the tonearm supports as shown above.
3. Save the tonearm supports. Reinsert them before transporting the Turntable.

(C) Stylus Protector

1. Locate and remove the stylus protector.
2. Save the stylus protector. Reinsert it before transporting the Turntable.

(D) Platter and Mat

1. Align the center hole in the *PLATTER* with the *SPINDLE* and slip it into position.
2. Place the belt over the motor pulley, taking care not to twist the belt.
3. Align the center hole in the *MAT* with the *SPINDLE* and place it on the *PLATTER*.

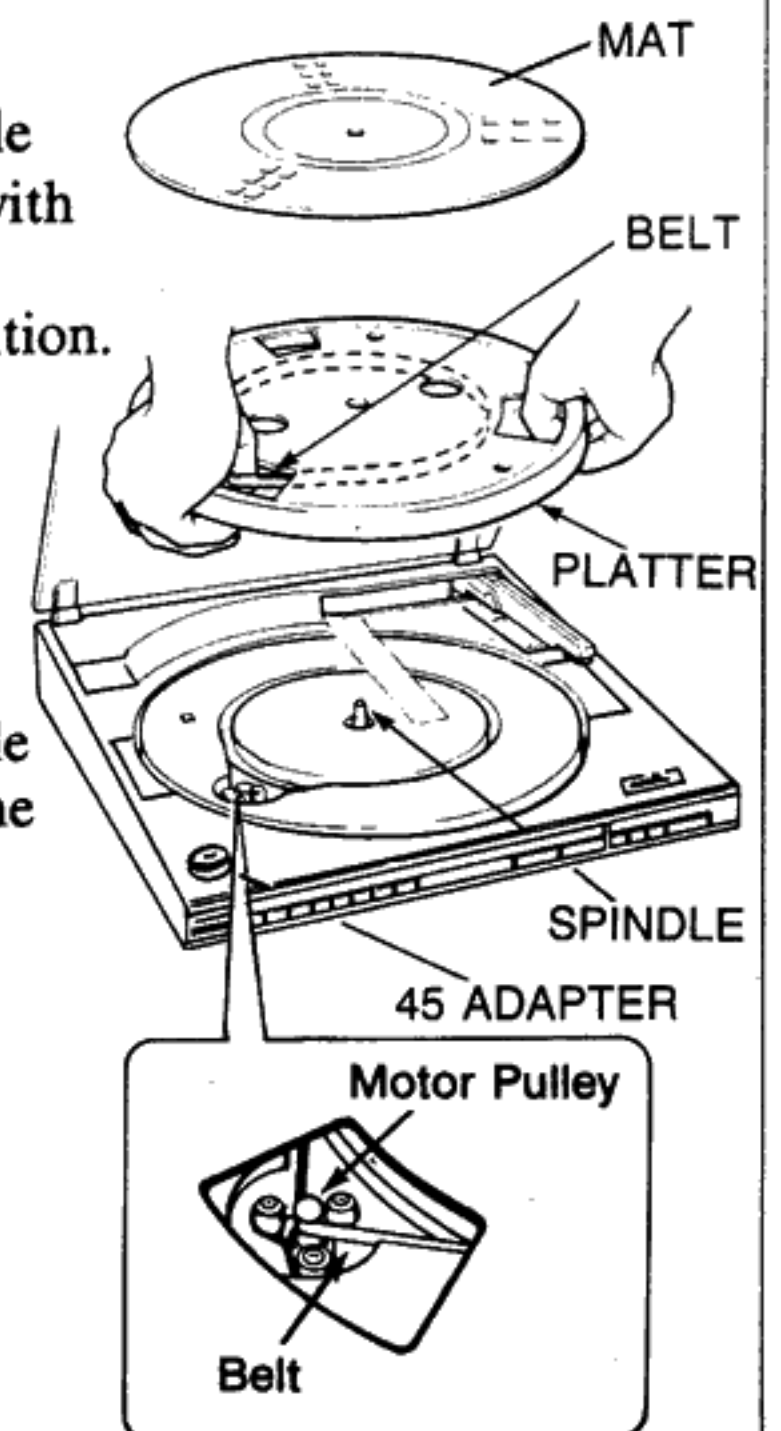

Unpacking

After you have removed the Turntable from its carton, three steps are required before you connect it to your stereo amplifier or receiver.

- A. Remove the shipping screws from the bottom of the unit.
- B. Remove the tonearm supports.
- C. Remove Plastic Stylus Protector
- D. Install the platter and its rubber mat.

(A) Shipping Screws

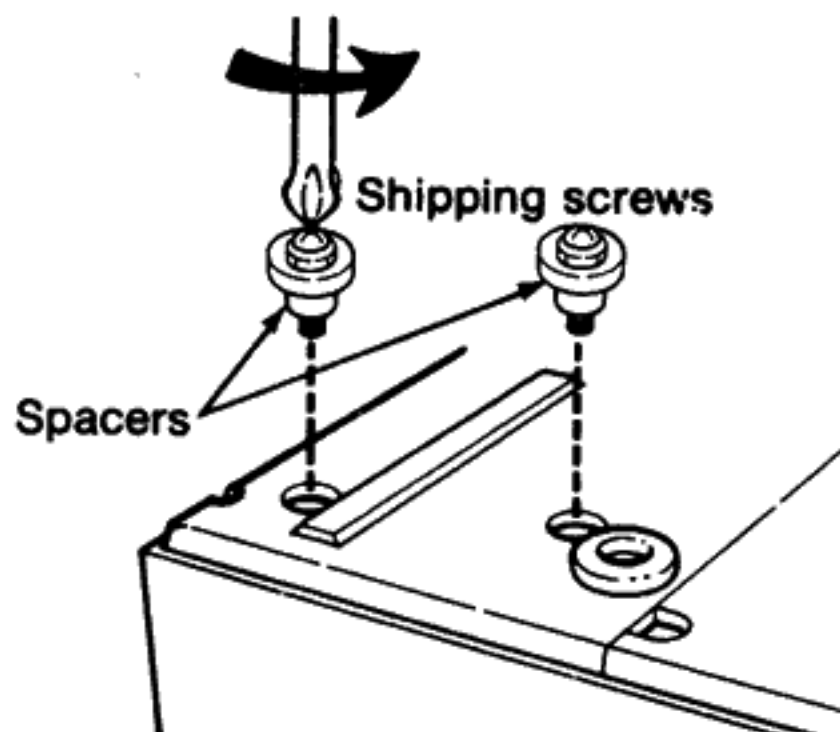

1. Place the Turntable upside down on a soft cloth.
2. Locate the two screws with the rubber spacers and remove them with a Phillips (cross-point) screwdriver.
3. Save the screws and spacers; reinstall them before transporting the Turntable.

Operating Controls

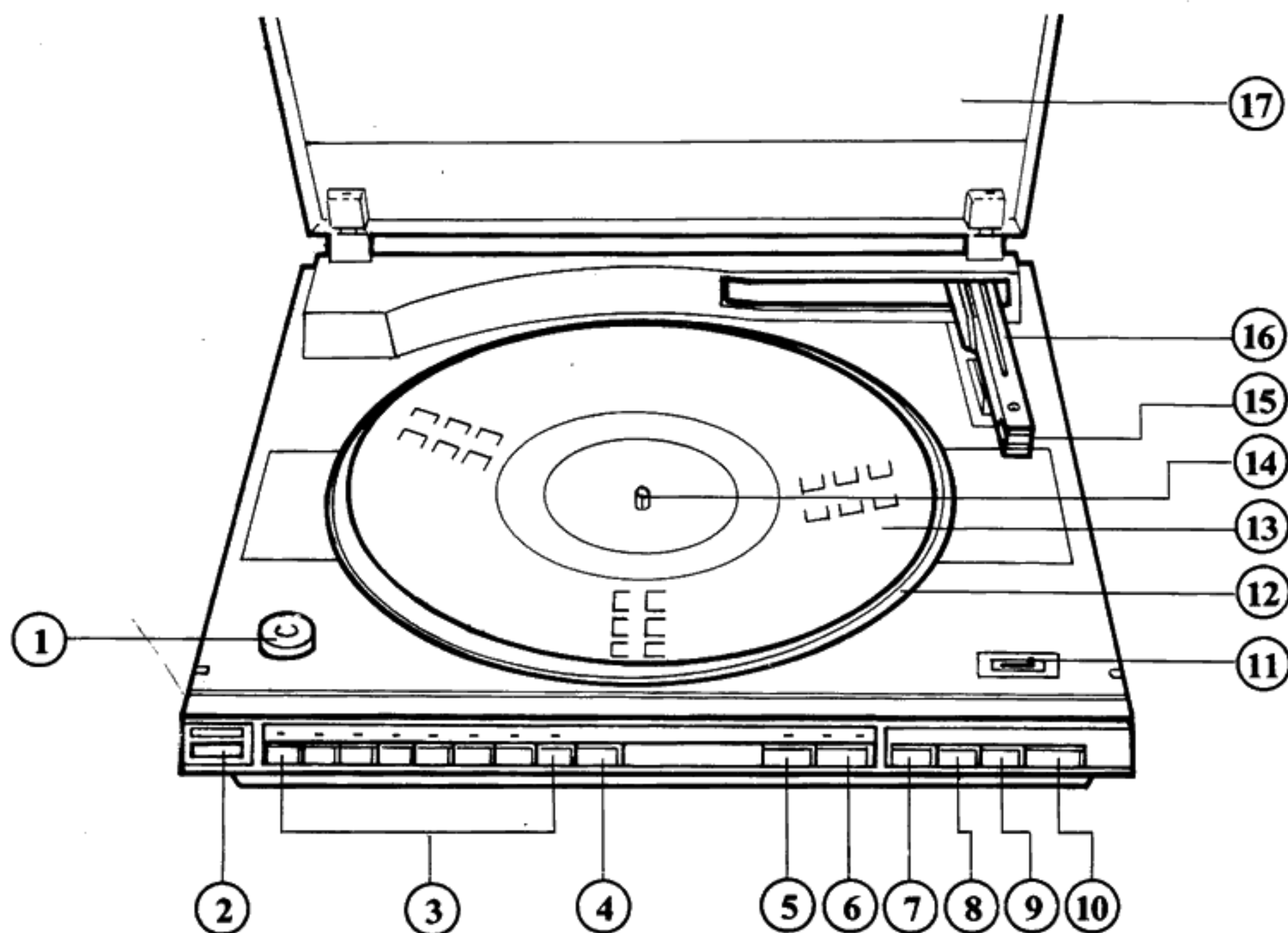

- ① **45 ADAPTER:** Place over *SPINDLE* in order to accommodate the large center hole of 45 RPM records.
- ② **POWER:** Alternately turns power on and off.
- ③ **PROGRAM Buttons:** These buttons select the track to be played, either immediately or as part of a programmed sequence. Lights above the buttons indicate which track is being selected during programming and which track is playing during *PROGRAMMED PLAY* mode.
- ④ **MEMORY/CLEAR:** Enters track selections into memory or clears the memory. See Page 6
- ⑤ **REPEAT:** Repeats entire record in *NORMAL PLAY*; repeats programmed selections in *PROGRAMMED PLAY*. During *REPEAT PLAY*, the indicator light above the button is on.
- ⑥ **SPEED:** Selection is automatic for standard records. Use this button for manual speed selection when playing non-standard records. Lights above the button indicate the speed selected. See Page 7.
- ⑦ **|◀◀ (FORWARD TRACK):** In *DIRECT ACCESS PLAY* or *PROGRAMMED PLAY* mode, press this button to skip to the next selection programmed into memory. In *NORMAL PLAY*, *STOP* or *PAUSE* mode, press this button to move the *TONEARM* toward the center of the record.
- ⑧ **▶▶| (BACKWARD SKIP):** Activates the same functions as the **|◀◀ (FORWARD SKIP)** button but in the opposite direction.
- ⑨ **STOP:** Stops play; returns *TONEARM* to its resting position.
- ⑩ **PLAY/PAUSE:** During the *STOP* or *PAUSE* mode, press this button to begin Turntable play. During *PLAY* mode, press this to raise and lower the *TONEARM* alternately.
- ⑪ **SCANNING SENSITIVITY Button:** Adjusts the optical system which determines record size and locates individual selections. For normal operation, this button should be set to *M*. See Page 7 for instructions on playing non-standard records.
- ⑫ **PLATTER**
- ⑬ **MAT**
- ⑭ **SPINDLE**
- ⑮ **CARTRIDGE**
- ⑯ **LINEAR TRACKING TONEARM** (referred to as *TONEARM* elsewhere in this manual)
- ⑰ **DUST COVER**

Manual Operation

Methods of Play

There are four basic methods of record playback:

- **NORMAL PLAY** for record playback from start to finish.
- **MANUAL PLAY** for non-standard record playback or to begin playback within a particular track.
- **DIRECT ACCESS PLAY** for record playback beginning at the start of any specified track (first through eighth on the record side).
- **PROGRAMMED PLAY** for playback of up to fifteen selections in any desired sequence, using the first through eighth tracks on the record side.

Inserting a Record

Follow these two steps regardless of which playback method you are using.

1. Press the **POWER** button.
2. Place the record over the **SPINDLE**. Use the **45 ADAPTER** if you are playing a 45 RPM record. Before performing any **PLAY** function, be sure to place a record on the Turntable. **The STYLUS could be damaged if it contacts the MAT or the edge of the record.**

Normal Play

1. Press the **PLAY/PAUSE** button. Playback will begin with the first track on the record and continue through the end of the side. The **TONEARM** will return to its resting position and **PLATTER** rotation will halt when record playback is completed.
2. To halt playback, press the **STOP** button at the desired point. The **TONEARM** will return to its resting position and **PLATTER** rotation will halt.

Manual Play

1. Press the **SPEED** button if you need to change the **PLATTER** rotation speed.
2. Use the **|◀◀ (FORWARD SKIP)** and **▶▶| (BACKWARD SKIP)** buttons to position the **TONEARM** above the record at the point where playback is to begin. When the **TONEARM** is in position, press the **PLAY/PAUSE** button to lower the **TONEARM** to the record and begin playback. Do not begin playback unless the stylus is over the record surface. **It could be damaged if it contacts the MAT or the outer edge of the record.**

Direct Access Play

1. Press the **PROGRAM** button corresponding with the number of the track with which you want to begin playback. The indicator light above the **PROGRAM** button will begin to flash.
2. Press the **PLAY/PAUSE** button. The indicator light above the desired **PROGRAM** button will stop flashing and stay on.
3. The optical system will scan the record. Playback will begin at the start of the track selected. If you have selected a track number higher than the number of tracks on the record side, the **PROGRAM** button indicator light will go off and Turntable rotation will halt.
4. After the optical system has scanned the record, playback will begin. During playback, the indicator light above the **PROGRAM** button corresponding with the track being played will light up.
5. You may interrupt record playback by pressing the **PLAY/PAUSE** button. This function operates identically during **DIRECT ACCESS PLAY** and **NORMAL PLAY**.
6. During playback, use the **|◀◀ (FORWARD SKIP)** button to skip to the next track and the **▶▶| (BACKWARD SKIP)** button to skip to the beginning of the current track.
7. If you press the **PLAY/PAUSE** button during the **DIRECT ACCESS PLAY** mode, the **|◀◀ (FORWARD SKIP)** and **▶▶| (BACKWARD SKIP)** buttons move the **TONEARM** toward the center or the outer edge of the record.

Manual Operation (cont)

Programmed Play

In order to use the *PROGRAMMED PLAY* mode, you first must place the Turntable in the *STOP* mode.

Before the Turntable can operate in the *PROGRAMMED PLAY* mode, you must indicate which tracks you want it to play and in what sequence. This process is known as "programming the memory."

You can program the memory to play the tracks on a record in any order. Any track can be played more than once. Since the memory can store up to fifteen entries, you could choose to play five selected tracks three times each in different sequences, three tracks five times, etc. You need not fill the memory every time you program it; you can choose to program only one track if you wish. Since there rarely are more than eight tracks on one side of a record, the Turntable has been designed to program only the first eight tracks.

The Turntable's memory essentially is a small computer. Like all computers, it must receive information in a specified form and sequence. The step-by-step programming procedure is as follows:

1. Press the numbered *PROGRAM* button corresponding with the first track you want to play. The indicator light above it will begin to flash.
2. Press the *MEMORY/CLEAR* button. The indicator light above the desired *PROGRAM* button will stop flashing and stay on.
3. Press the numbered *PROGRAM* button corresponding with the second track you want to play. The indicator light above it will begin to flash.
4. Press the *MEMORY/CLEAR* button again. The indicator light above the *PROGRAM* button will stop flashing and stay on.

If you accidentally press the wrong *PROGRAM* button, press the correct one before pressing the *MEMORY/CLEAR* button. After you have pressed *MEMORY/CLEAR*, you cannot change a selection without cancelling ("clearing") your entire program and beginning again.

You can clear the entire program by pressing *MEMORY/CLEAR* twice. If you clear the memory while you are programming it, begin again.

Playback of Programmed Selections

After you have programmed the memory, simply press the *PLAY/PAUSE* button to start playback of your selections. The optical system will scan the record to locate the beginning of each selection. Playback will begin once scanning is completed. As each track begins

to play, the indicator light above the corresponding *MEMORY/PROGRAM* button will light up. When the last selection in your program has been played, the *TONEARM* will return to its resting position and *PLATTER* rotation will halt.

The *PLAY/PAUSE* button operates identically in *PROGRAMMED PLAY* and *NORMAL PLAY*. To halt playback and return the *TONEARM*, press the *STOP* button.

1. During playback, use the |◀◀ (*FORWARD SKIP*) and ▶▶| (*BACKWARD SKIP*) buttons to skip to the track before or after the track in the program memory.
2. If you press the *PLAY/PAUSE* button during the *PROGRAMMED PLAY* mode, the |◀◀ (*FORWARD SKIP*) and ▶▶| (*FORWARD SKIP*) buttons move the *TONEARM* toward the center or the outer edge of the record and clear the program memory. When you resume playback after moving the *TONEARM*, the Turntable will play to the end of the record and stop. Pressing any of the following buttons during the *PROGRAMMED PLAY* mode will clear the program memory:
 - The *STOP* button
 - The *PLAY/PAUSE* button followed by either the |◀◀ (*FORWARD SKIP*) or the ▶▶| (*BACKWARD SKIP*) button.

Repeat Play

Press the *REPEAT* button to begin repeat playback. The indicator light above the *REPEAT* button comes on to show that the *REPEAT PLAY* mode is operating. *REPEAT PLAY* will continue for sixteen plays, then stop and turn off automatically.

You can halt the *REPEAT PLAY* mode at any time by pressing the *REPEAT* button again. The indicator light above the *REPEAT* button will go out. Record play will continue until the end of the record side (or until the end of the programmed sequence in *PROGRAMMED PLAY* mode).

1. Do not use the *REPEAT* button during the *MANUAL PLAY* mode.
2. If you activate *REPEAT PLAY* during the *NORMAL PLAY* mode, the entire record will be repeated.
3. If you activate *REPEAT PLAY* during the *DIRECT ACCESS PLAY* mode, the entire record will be repeated.
4. If you activate *REPEAT PLAY* during the *PROGRAMMED PLAY* mode, only the programmed tracks will be repeated.

Additional Information

Playing Non-Standard Records

Your Turntable uses a sophisticated optical system to detect the size of the record placed on the *PLATTER* and the location of the unrecorded bands between the tracks. The system relies on the difference between the amount of light reflected off the platter *MAT* and off the outer rim of the record to determine record size. It relies on the difference between the reflectivity of the smooth surface between tracks and the grooved surface of the recorded tracks to locate the start of each track. The optical system can tolerate normal variations in the appearance of good-quality records which meet industry standards for size, material, recording technique, etc. Records which have been damaged or which do not conform to industry standards may need to be played in the *MANUAL PLAY*

Some non-standard records may be played in the *DIRECT ACCESS PLAY* and *PROGRAMMED PLAY* modes if the setting of the *SCANNING SENSITIVITY* button is changed. For playback of standard records, this switch should be set to the *M* position. Changing the sensitivity setting to *L* or *H* may improve optical system operation in some instances. Consult the table below.

NOTE: The unrecorded surfaces at the outer edge of the record, between tracks and following the end of the last track on the side are called "lands" in the following table.

<i>RECORD TYPE OR CONDITION</i>	<i>PROCEDURE</i>
33 1/3 RPM, not 12" in diameter	Set <i>SPEED</i> to 33 1/3 and play manually
45 RPM, not 7" in diameter	Set <i>SPEED</i> to 45 and play manually
Transparent, translucent, non-black or has printed image on surface	Play manually
Warped or eccentric (hole not centered)	Play manually
Dirty or scratched	Clean if possible or play manually
Very short tracks	Use <i>NORMAL PLAY</i> (these may be skipped in <i>DIRECT ACCESS PLAY</i> and <i>PROGRAMMED PLAY</i>)
Very narrow lands between tracks	Set <i>SCANNING SENSITIVITY</i> button to <i>H</i> or use <i>NORMAL PLAY</i>
Recorded grooves in track very rough or widely separated	Set <i>SCANNING SENSITIVITY</i> button to <i>L</i> or use <i>NORMAL PLAY</i>
Unusual shape (heart-shaped, square, etc.)	Play manually

Adjusting Point of Stylus Descent

The descent position on the first track of the disc is not user adjustable. The stylus ascent/descent position for tracks other than the first track has been adjusted before delivery. However, if the stylus sets down before or after the beginning of a track perform the following adjustment procedure.

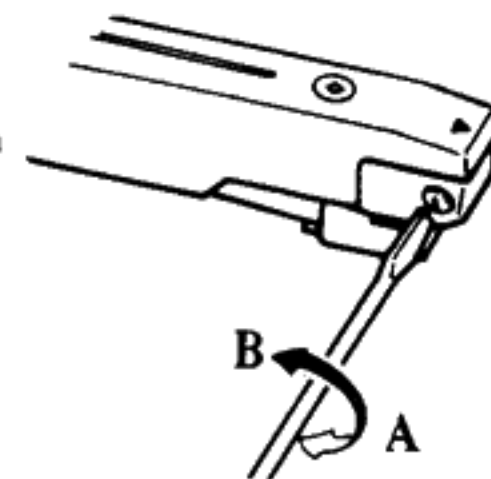

1. Choose a 12-inch 33-1/3 RPM disc that has none of the faults in the preceding table. It will be helpful if you are familiar with its program content.
2. Obtain a small crosspoint (Phillips) screwdriver to turn the adjusting screw.
3. Use Programmed Play to start play at the second or a subsequent track.
4. Note the point at which the track begins to play:
 - * If play begins too late
Turn the screw counter clockwise (illustrated above with the letter B).
 - * If play begins too soon (possibly near the end of the preceding track)
Turn the screw clockwise (illustrated above with the letter A).

NOTE: A full turn of the adjusting screw changes the point of descent about 0.35 *MILIMETERS* (slightly less than 1/72 inch). This is roughly 2-1/2 to 3 revolutions of most discs.

5. Repeat Step 4 as required.

Stylus Replacement

If sound becomes distorted or noisy, check the stylus for accumulated dust. To clean the stylus, use a stylus cleaner

If cleaning does not correct the problem, have the stylus checked for wear. The typical playing life of a diamond stylus is approximately 700 hours.

1. Press the *POWER* button.
2. Press and hold the | ◀◀ (*FORWARD SKIP*) button on the Turntable to move the *TONEARM* approximately 2" from its resting position.
3. Grasp the stylus as shown and gently pull it downward.
4. Install the new stylus by slipping it into position.

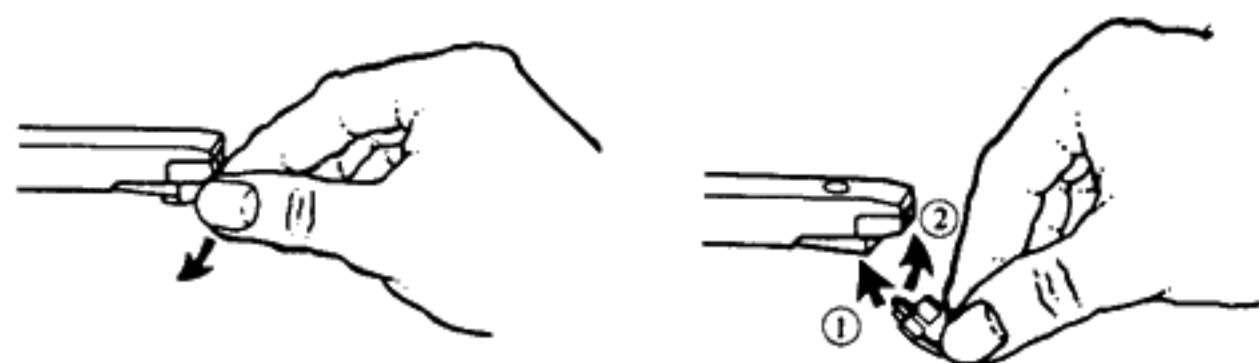

For Continued Enjoyment

Cleaning

Dust the exposed surfaces as required using a soft cloth or the dusting attachment of your vacuum cleaner. Some of the plastic surfaces are easily scratched; they can be marred by alcohol and various solvents. Glass wax applied with a soft cloth or tissue will restore the original sparkle. Avoid excessive use of oil-based furniture polishes since the materials used in this cabinet are non-porous and the residue will accumulate more dust.

Turn the Turntable off before cleaning it. This disables all controls except the *POWER* button. When you are cleaning or dusting the back of the Turntable, be especially careful not to loosen any connections.

Heat and Moisture Protection

Place the Turntable on a hard, level surface which is large enough to allow all four mounting feet to rest on it. Do not allow other electronic components, deep-pile mats, rugs, etc. to obstruct the ventilation holes in your equipment's cabinets.

Turntable placement on top of a speaker cabinet is not recommended; vibrations may be transmitted to the *PLATTER* and *TONEARM*, resulting in sound distortion and feedback.

Trouble Checks

Does Not Turn On

- Make sure the power cord is firmly seated in the power outlet.
- Make sure the receptacle is operational by plugging some other device into the same socket for a test.

No Sound

- Make sure the Turntable has been selected as the playback source.

Hum

- Make sure the ground wire in the phonograph cable is attached to the ground screw on the amplifier.
- Make sure the cable is completely plugged into the jacks on the amplifier.

Very Low Volume

- Check the *CARTRIDGE*.

Sound Distorted or Noisy

- Check the stylus for wear. Replace it if necessary. A worn stylus can damage your records.
- Make sure your records are clean. Use record cleaning materials (available from record stores and audio equipment stores) or mild detergent and a soft cloth.
- Make sure your stylus is free from dust. Clean it regularly with a stylus cleaner.

Skips some Tracks in *PROGRAMMED PLAY*

- See the table on Page 9 for additional information.

Specifications

Turntable Type	2-speed, belt-drive fully automatic turntable
Platter Drive	DC servo motor
Speeds	33 1/3 and 45 RPM, automatically switched by record size, with manual override
Platter	11 5/8" diameter, die-cast aluminum alloy
Signal-to-Noise (S/N) Ratio	>65 dB (DIN-B)
Wow and Flutter	0.06% (WRMS)
Power Requirement	9.5 watts at 120 volts, 60 Hz
Dimensions	(W)16 1/2" × (D)14 11/16" × (H)4"
Weight (approx.)	9 lbs.

Tonearm

Type	Linear tracking
Effective Length (approx.)	5 3/8"

Cartridge

Type	Dual magnet
Stylus DS-ST16	Diamond
Frequency Range	10 Hz to 25 kHz
Output Voltage	2.5 mV at 1 kHz at 50mm/sec.
Channel Difference	0.5 dB at 1 kHz
Channel Separation	23 dB at 1 kHz
Tracking Force	2 grams

NOTE: Specifications are subject to change without notice.

Transporting the Turntable

To prepare the turntable for shipping, perform the following steps before disconnecting the power cord plug.

1. Press the *POWER* button to turn off the Turntable.
2. After the *TONEARM* has reached its resting position, remove the Turntable *MAT* and *PLATTER*.
3. Install the tonearm support and plastic stylus protector as shown on page 3.
4. Remove the power cord plug from the wall outlet and place the Turntable upside down on a soft cloth.
5. Install the spacers and shipping screws. (Refer to Page 3 for correct procedures.)
6. Use the original outside packing materials and carton to ship or transport the Turntable.

Removing Dust Cover

The dust cover can be removed by first opening the lid and then lifting up as shown. This gives you additional flexibility when positioning your Turntable in an audio rack or furniture stand. If your rack has limited space, you can remove the dust cover.

